

GWS 20-180 GWS 20-230 GWS 24-180 H GWS 24-230 H PROFESSIONAL

BOSCH
Ideas that work.

* Des idées en action.

Operating instructions

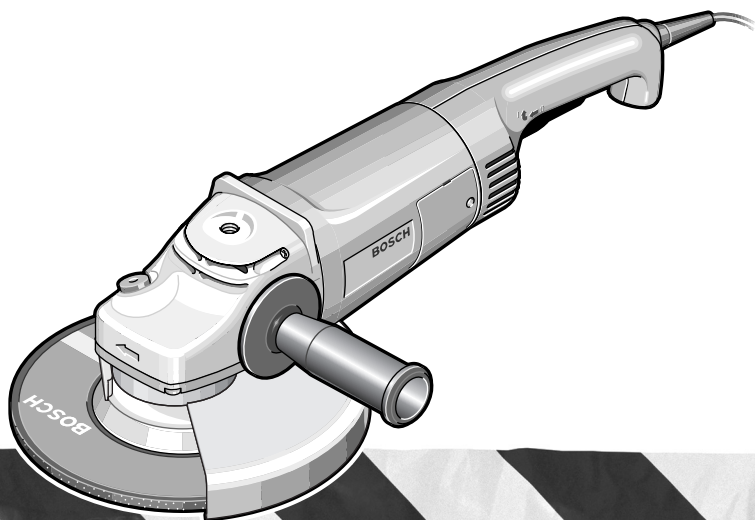

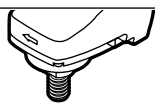

1 605 703 099



1 600 210 039

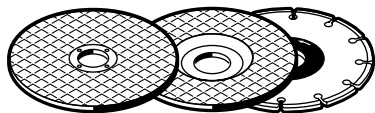

SDS-clip 1 603 340 031

1 603 340 040



1 607 950 048

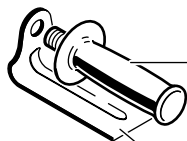

2 602 025 075

1 601 329 013



Ø 180 mm 1 605 510 222

Ø 230 mm 1 605 510 223



Ø 180 mm 2 605 510 173

Ø 230 mm 2 605 510 174

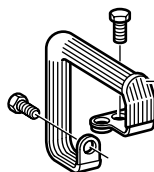

1 607 000 247

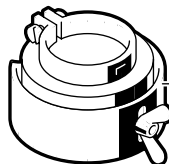

1 605 510 181



1 605 703 099

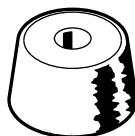

16 1 608 600 231

24 1 608 600 232

36 1 608 600 233

60 1 608 600 234



24 1 608 600 239

36 1 608 600 240

60 1 608 600 241



1 603 340 040



1 607 950 004

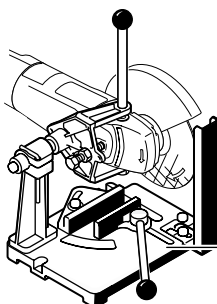

0 601 999 018

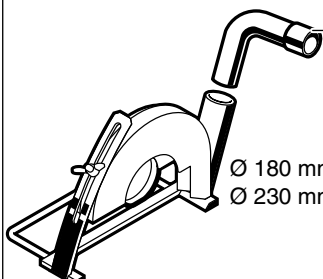

1 600 793 007

Ø 180 mm 1 605 510 179

Ø 230 mm 1 605 510 180

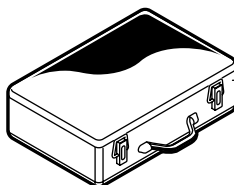

1 605 438 034

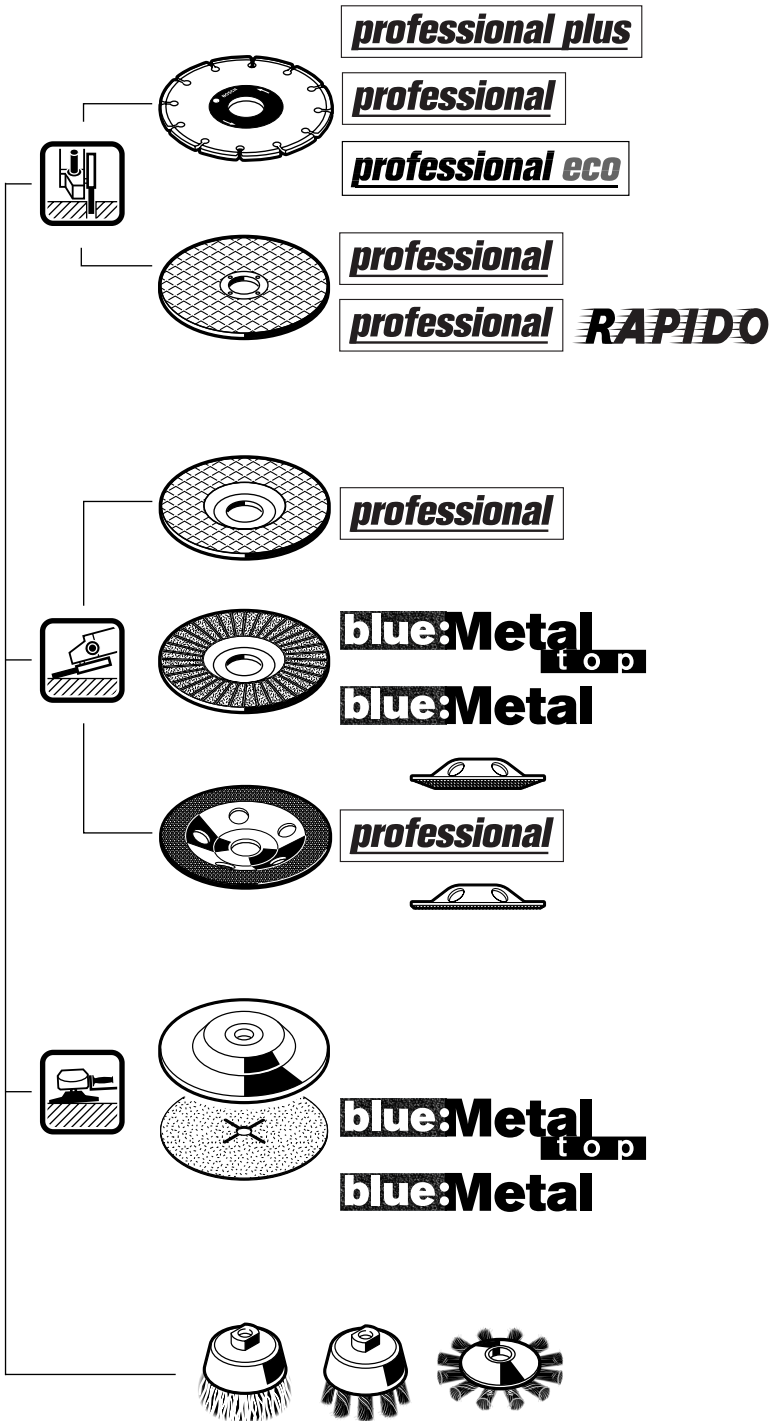

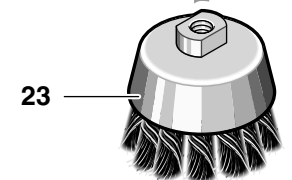
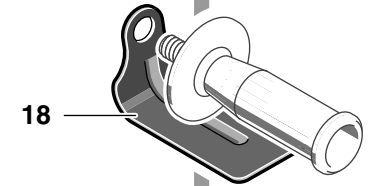
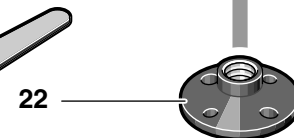
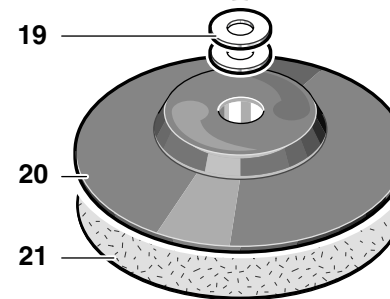
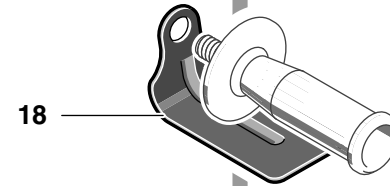
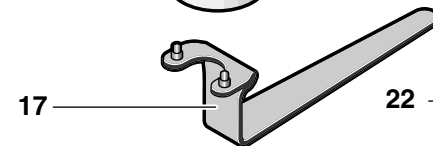
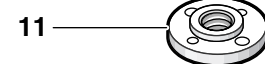
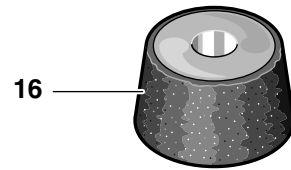
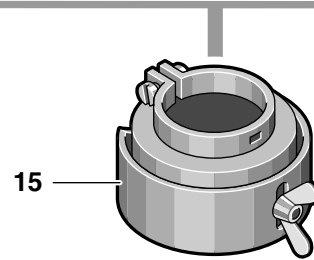
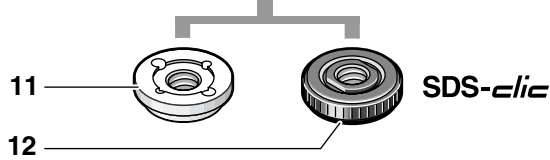
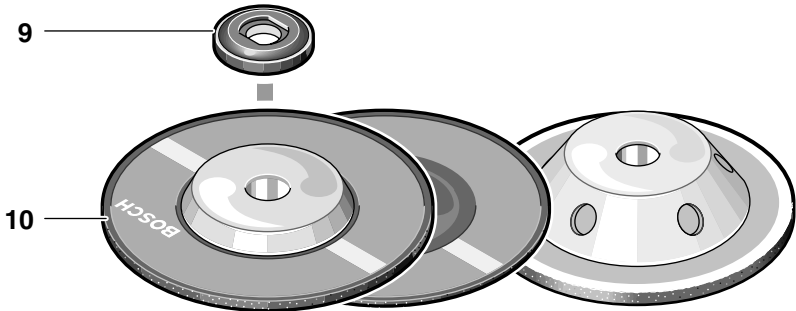
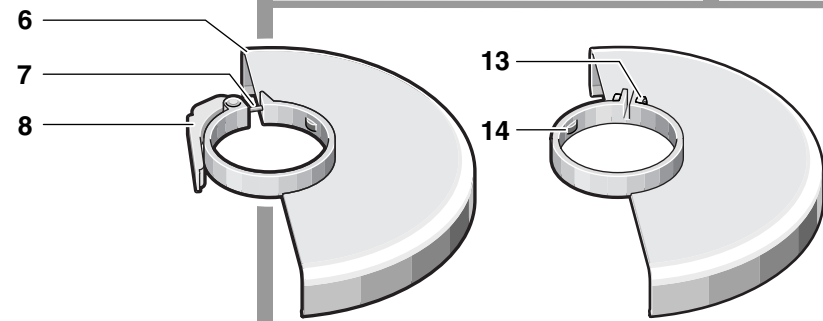
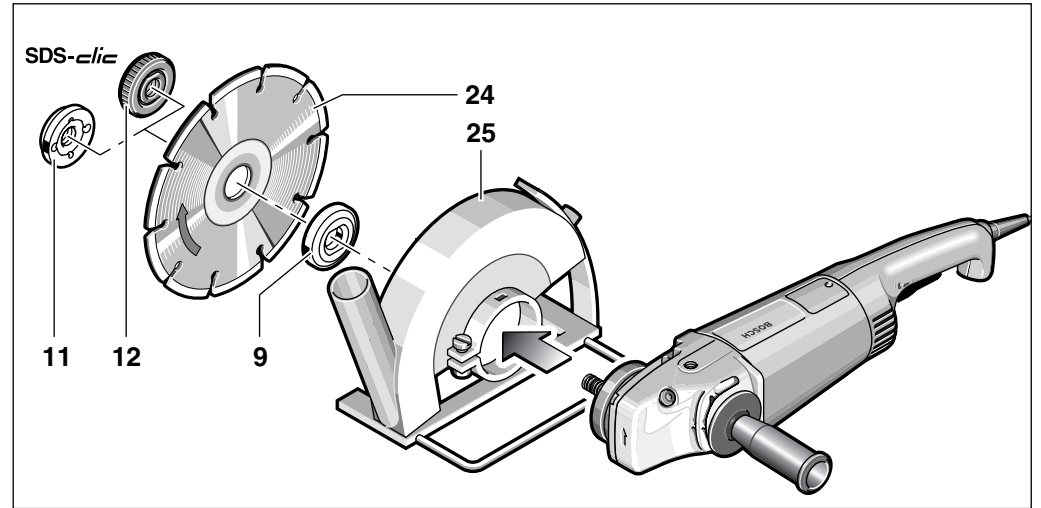
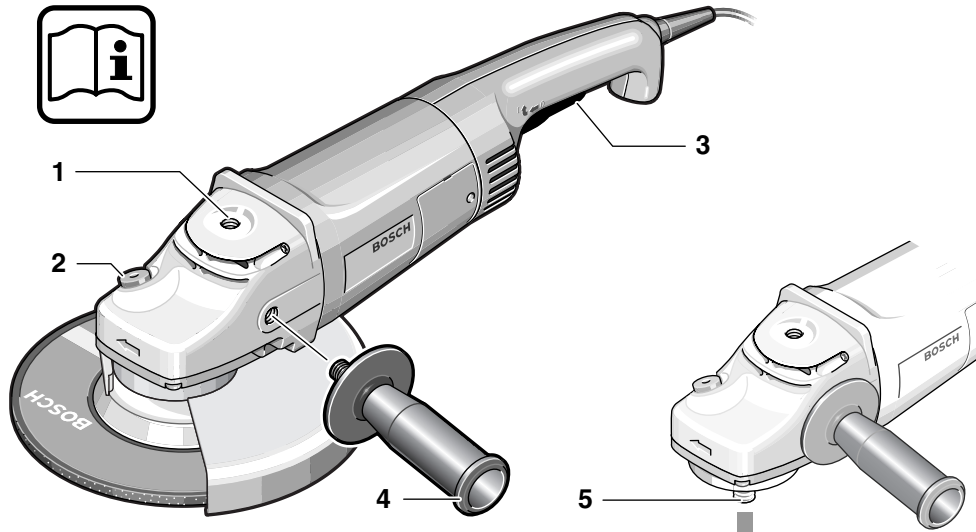

**GWS 24-180 H
GWS 24-230 H
PROFESSIONAL**

General Safety Rules

WARNING! Read all instructions. Failure to follow all instructions listed below may result in electric shock, fire and/or serious injury. The term "power tool" in all of the warnings listed below refers to your mains operated (corded) power tool or battery operated (cordless) power tool.

SAVE THESE INSTRUCTIONS.

1) Work area

- a) **Keep work area clean and well lit.** Cluttered and dark areas invite accidents.
- b) **Do not operate power tools in explosive atmospheres, such as in the presence of flammable liquids, gases or dust.** Power tools create sparks which may ignite the dust or fumes.
- c) **Keep children and bystanders away while operating a power tool.** Distractions can cause you to lose control.

2) Electrical safety

- a) **Power tool plugs must match the outlet. Never modify the plug in any way. Do not use any adapter plugs with earthed (grounded) power tools.** Unmodified plugs and matching outlets will reduce risk of electric shock.
- b) **Avoid body contact with earthed or grounded surfaces such as pipes, radiators, ranges and refrigerators.** There is an increased risk of electric shock if your body is earthed or grounded.
- c) **Do not expose power tools to rain or wet conditions.** Water entering a power tool will increase the risk of electric shock.
- d) **Do not abuse the cord. Never use the cord for carrying, pulling or unplugging the power tool. Keep cord away from heat, oil, sharp edges or moving parts.** Damaged or entangled cords increase the risk of electric shock.
- e) **When operating a power tool outdoors, use an extension cord suitable for outdoor use.** Use of a cord suitable for outdoor use reduces the risk of electric shock.

3) Personal safety

- a) **Stay alert, watch what you are doing and use common sense when operating a power tool. Do not use a power tool while you are tired or under the influence of drugs, alcohol or medication.** A moment of inattention while operating power tools may result in serious personal injury.
- b) **Use safety equipment. Always wear eye protection.** Safety equipment such as dust mask, non-skid safety shoes, hard hat, or hearing protection used for appropriate conditions will reduce personal injuries.
- c) **Avoid accidental starting. Ensure the switch is in the off position before plugging in.** Carrying power tools with your finger on the switch or plugging in power tools that have the switch on invites accidents.

- d) **Remove any adjusting key or wrench before turning the power tool on.** A wrench or a key left attached to a rotating part of the power tool may result in personal injury.
- e) **Do not overreach. Keep proper footing and balance at all times.** This enables better control of the power tool in unexpected situations.
- f) **Dress properly. Do not wear loose clothing or jewellery. Keep your hair, clothing and gloves away from moving parts.** Loose clothes, jewellery or long hair can be caught in moving parts.
- g) **If devices are provided for the connection of dust extraction and collection facilities, ensure these are connected and properly used.** Use of these devices can reduce dust related hazards.

4) Power tool use and care

- a) **Do not force the power tool. Use the correct power tool for your application.** The correct power tool will do the job better and safer at the rate for which it was designed.
- b) **Do not use the power tool if the switch does not turn it on and off.** Any power tool that cannot be controlled with the switch is dangerous and must be repaired.
- c) **Disconnect the plug from the power source before making any adjustments, changing accessories, or storing power tools.** Such preventive safety measures reduce the risk of starting the power tool accidentally.
- d) **Store idle power tools out of the reach of children and do not allow persons unfamiliar with the power tool or these instructions to operate the power tool.** Power tools are dangerous in the hands of untrained users.
- e) **Maintain power tools. Check for misalignment or binding of moving parts, breakage of parts and any other condition that may affect the power tools operation. If damaged, have the power tool repaired before use.** Many accidents are caused by poorly maintained power tools.
- f) **Keep cutting tools sharp and clean.** Properly maintained cutting tools with sharp cutting edges are less likely to bind and are easier to control.
- g) **Use the power tool, accessories and tool bits etc., in accordance with these instructions and in the manner intended for the particular type of power tool, taking into account the working conditions and the work to be performed.** Use of the power tool for operations different from those intended could result in a hazardous situation.

5) Battery tool use and care

- a) **Ensure the switch is in the off position before inserting battery pack.** Inserting the battery pack into power tools that have the switch on invites accidents.
- b) **Recharge only with the charger specified by the manufacturer.** A charger that is suitable for one type of battery pack may create a risk of fire when used with another battery pack.

- c) **Use power tools only with specifically designated battery packs.** Use of any other battery packs may create a risk of injury and fire.
- d) **When battery pack is not in use, keep it away from other metal objects like paper clips, coins, keys, nails, screws, or other small metal objects that can make a connection from one terminal to another.** Shorting the battery terminals together may cause burns or a fire.
- e) **Under abusive conditions, liquid may be ejected from the battery; avoid contact. If contact accidentally occurs, flush with water. If liquid contacts eyes, additionally seek medical help.** Liquid ejected from the battery may cause irritation or burns.
- 6) **Service**
- a) **Have your power tool serviced by a qualified repair person using only identical replacement parts.** This will ensure that the safety of the power tool is maintained.

Tool Specifications

Angle Grinder		GWS 20-180 PROFESSIONAL	GWS 20-230 PROFESSIONAL	GWS 24-180 H PROFESSIONAL	GWS 24-230 H PROFESSIONAL
Order number		0 601 849 1..	0 601 850 1..	0 061 853 4..	0 601 854 4..
Rated input power*	[W]	2 000	2 000	2 400	2 400
Output power	[W]	1 250	1 250	1 700	1 700
No-load speed	[rpm]	8 500	6 500	8 500	6 500
Grinding disc dia., max.	[mm]	180	230	180	230
Grinder spindle thread		M 14	M 14	M 14	M 14
Weight without cable, approx.	[kg]	4.2	4.2	5.1	5.1
Protection class		□ / II	□ / II	□ / II	□ / II

* The values given are valid for nominal voltages [U] of 230/240 V. For lower voltages and models for specific countries, these values can vary.

Please observe the order number of your machine. The trade names of the individual machines may vary.

Inrush currents cause short-time voltage drops. Under unfavourable power supply conditions, other equipment may be affected. If the system impedance of the power supply is lower than 0,25 Ohm, disturbances are unlikely to occur.

Machine Elements

The numbering of the device elements refers to the illustration of the machine on the graphics page.

While reading the operating instructions, unfold the graphics page for the device and leave it open.

- 1 Thread for auxiliary handle (3x)
- 2 Spindle lock button
- 3 On/Off switch
- 4 Auxiliary handle
- 5 Grinder spindle
- 6 Protection guard
- 7 Adjustment screw*
- 8 Clamping lever*
- 9 Mounting flange with O-ring
- 10 Grinding/cutting disc*
- 11 Clamping nut
- 12 *sds-plus* quick-clamping nut*

- 13 Clamping screw
- 14 Coded projection
- 15 Guard, grinding cup*
- 16 Grinding cup*
- 17 Two-pin spanner for clamping nut*
- 18 Hand guard*
- 19 Spacer discs*
- 20 Rubber sanding plate*
- 21 Sanding sheet*
- 22 Round nut*
- 23 Cup brush*
- 24 Diamond cutting disc*
- 25 Cutting guide with dust extraction protection guard*
- 26 Cutting grinder stand*

* Not all of the accessories illustrated or described are included as standard delivery.



For Your Safety

Working safely with this machine is possible only when the operating and safety information are read completely and the instructions contained therein are strictly followed. In addition, the general safety notes in the enclosed booklet must be observed. Before using for the first time, ask for a practical demonstration.

- Wear protective glasses and hearing protection.
- Wear additional protection equipment for your safety, such as protective gloves, sturdy shoes, hard hat and apron.
- The dust that is produced while working can be detrimental to health, inflammable or explosive. Suitable safety measures are required. Examples: Some dusts are regarded as carcinogenic. Use suitable dust/chip extraction and wear a dust respirator.
- Dust from light alloys can burn or explode. Always keep the workplace clean, as blends of materials are particularly dangerous.
- If the mains cable is damaged or cut through while working, do not touch the cable but immediately pull the mains plug. Never use the machine with a damaged cable.
- Connect machines that are used in the open via a residual current device (RCD) with an actuating current of 30 mA maximum. Do not operate the machine in rain or moisture.
- When working with the machine, always hold it firmly with both hands and provide for a secure stance.
- **Secure the workpiece.** A workpiece clamped with clamping devices or in a vice is held more secure than by hand.
- Always direct the cable to the rear away from the machine.
- Always switch the machine off and wait until it has come to a standstill before placing it down.
- For power outage or when the mains plug is pulled, unlock the On/Off switch immediately and turn it to the off position. This prevents uncontrolled restarting.
- The machine must be used only for dry cutting/grinding.
- For all work with the machine, the auxiliary handle must be mounted.
- **Hold the power tool only by the insulated gripping surfaces, when performing an operation where the cutting tool may run into hidden wiring or its own cord.**
Contact with a "live" wire will make exposed metal parts of the tool "live" and shock the operator.
- **Use appropriate detectors to determine if utility lines are hidden in the work area or call the local utility company for assistance.**
Contact with electric lines can lead to fire and electric shock. Damaging a gas line can lead to explosion. Penetrating a water line causes property damage or may cause an electric shock.
- For work with grinding or cutting discs, the protection guard **6** must be mounted. For work with the rubber sanding plate **20** or with the cup brush **23**/disc brush/flap disc, the hand guard **18** (accessory) is to be mounted.
- Use dust extraction when working with stone. The vacuum cleaner must be approved for masonry dust. When cutting stone, use the cutting guide.
- Do not work with materials containing asbestos.
- Use only grinding tools with a permissible speed at least as high as the no-load speed of the machine.
- Check grinding tools before use. The grinding tool must be properly mounted and turn freely. Perform a test run for at least 30 seconds without load. Do not use damaged, out-of-round or vibrating grinding tools.
- Protect the grinding tool from impact, shock and grease.
- Apply the machine to the workpiece only when switched on.
- Keep hands away from rotating grinding tools.
- Pay attention to the direction of rotation. Always hold the machine so that sparks and grinding dust fly away from the body.
- When grinding metal, flying sparks are produced. Take care that no persons are endangered. Due to danger of fire, no combustible materials should be located in the vicinity (spark flight zone).
- Be careful when cutting grooves, e. g. in structural walls: See Information on Structures.
- Blocking the cutting disc leads to jerking reaction forces on the machine. In this case switch off the machine immediately.

- Pay attention to the dimensions of the grinding disc. The mounting hole diameter must fit the mounting flange **9** without play. Do not use reducers or adapters.
- Never use cutting discs for rough grinding. Do not exert any lateral pressure on the cutting discs.
- Observe the manufacturer's instructions for mounting and using grinding tools.
- Caution! The grinding tool runs on after the machine is switched off.
- Do not clamp the machine in a vice.
- Never allow children to use the machine.
- Bosch is only able to ensure perfect operation of the machine if the original accessories intended for it are used.



Mounting the Protective Devices

- **Before any work on the machine itself, pull the mains plug.**
- **For work with grinding or cutting discs, the protection guard **6** must be mounted.**

Protection Guard with Locking Screw

The coded projection **14** on the protection guard **6** ensures that only a guard that fits the machine type can be mounted.

Loosen the clamping screw **13**, if necessary.

Place the protection guard **6** with coded projection **14** into the coded groove on the spindle collar of the machine head and rotate to the required position (working position).

The closed side of the protection guard **6 must always point to the operator.**

Tighten clamping screw **13**.

Protection Guard with Quick Clamp

 The protection guard is preadjusted to the diameter of the spindle collar. If required, the tightening tension of the clamping bracket can be changed by tightening or loosening the adjustment screw **7**. Always ensure that the protection guard **6** is seated tightly on the spindle collar.

Open the clamping lever **8**.

Place the protection guard **6** on the spindle collar of the machine head and turn to the required position (working position).

To fasten the protection guard **6**, close the clamping lever **8**.

The closed side of the protection guard **6 must always point to the operator.**

Auxiliary Handle

- **For all work with the machine, the auxiliary handle must be mounted.**

Screw the auxiliary handle **4** into the head of the machine according to the working method.

Do not continue to use an auxiliary handle if it is damaged.

Hand Guard

For work with the rubber sanding plate **20** or with the cup brush **23**/disc brush/flap disc, the hand guard **18** (accessory) is to be mounted. The hand guard **18** is fastened with the auxiliary handle **4**.

Intended Use

The machine is intended for cutting, roughing and brushing metal and stone materials without using water. For cutting stone, a cutting guide is required.

Information on Structures

Slots in structural walls are subject to the Standard DIN 1053, Part 1 or country-specific regulations.

These regulations are to be observed under all circumstances. Before beginning work, consult the responsible structural engineer, architects or the construction supervisor.

Mounting the Grinding Tools

- Before any work on the machine itself, pull the mains plug.



Use only grinding tools with a permissible speed at least as high as the no-load speed of the machine.

Grinding and cutting discs become very hot while working; do not touch until they have cooled.

- Clean the grinder spindle and all parts to be mounted. For clamping and loosening the grinding tools, lock the grinder spindle 5 with the spindle lock button 2.

Actuate the spindle lock button 2 only when the grinder spindle is at a standstill!

Grinding/Cutting Disc

Pay attention to the dimensions of the grinding disc. The mounting hole diameter must fit the mounting flange 9 without play. Do not use reducers or adapters.

When using a diamond cutting disc, take care that the direction-of-rotation arrow on the diamond cutting disc and the direction of rotation of the machine (direction-of-rotation arrow on the machine head) agree.

For mounting, see the illustration page.

Screw on the clamping nut 11 and tighten with the two-pin spanner (see Section "Quick-clamping Nut").

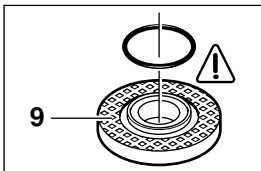

An O-ring (plastic part) is inserted in the mounting flange 9 around the spigot.

If the O-ring is missing or is damaged, it must in all cases be replaced (Order No. 1 600 210 039) before the mounting flange 9 is mounted.

- ☞ After mounting the grinding tool and before switching on, check that the grinding tool is correctly mounted and that it can turn freely.

Flap Disc

Depending on the application, remove the protection guard 6 and mount the hand guard 18. Place the special mounting flange 9 (accessory, Order No. 2 605 703 028) and the flap disc on the grinder spindle 5. Screw on the clamping nut 11 and tighten with the two-pin spanner.

Rubber Sanding Plate 20

Depending on the application, remove the protection guard 6 and mount the hand guard 18.

Before mounting the rubber sanding pad 20, place the 2 spacers 19 onto the grinding spindle.

For mounting, see the illustration page.

Screw on the round nut 22 and tighten with the two-pin spanner.

Cup Brush 23/Disc Brush

Depending on the application, remove the protection guard 6 and mount the hand guard 18.

The grinding tool must be able to be screwed onto the grinding spindle 5 until it rests firmly against the grinder spindle flange at the end of the grinder spindle threads. Tighten with an open-end spanner.

Grinding Cup

- ⚠ When working with grinding cups, use the special guard 15.

The grinding cup 16 should always protrude from the guard 15 only as far as absolutely necessary for the work to be performed in each case.

Adjust the guard 15 to this distance.

For mounting, see the illustration page.

Screw on the clamping nut 11 and tighten with the fitting offset two-pin spanner 17.

Quick Clamping Nut SDS-*clic*

Instead of the clamping nut 11, the quick-clamping nut 12 (accessory) can be used. Grinding tools can then be mounted without using tools.

The quick-clamping nut 12 may be used only for grinding and cutting discs.

Use only a flawless, undamaged quick-clamping nut 12.

When screwing on, take care that the side with printing does not point to the grinding disc. The arrow must point to the index mark 27.

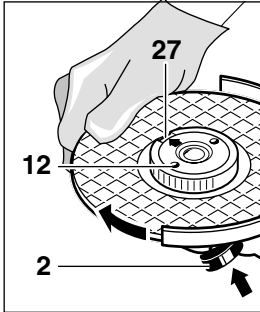

Lock the grinder spindle with the spindle lock button 2. Tighten the quick-clamping nut by forcefully turning the grinding disc in the clockwise direction.

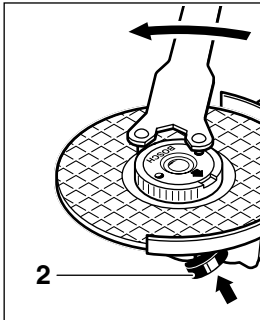

A properly tightened undamaged, quick-clamping nut can be loosened by hand turning the knurled ring in anticlockwise direction.

Never loosen a tight quick-clamping nut with pliers but use a two-pin spanner. Insert the two-pin spanner as shown in the illustration.

Approved Grinding Tools

All grinding tools mentioned in this operating manual instruction can be used.

The permissible speed [rpm] or the circumferential speed [m/s] of the grinding tools used must at least match the values given in the table.

Therefore, always observe the **permissible rotational/circumferential speed** on the label of the grinding tool.

	max. [mm]		[mm]	[rpm]	[m/s]
	D	b			
	180 230	8 8	22.2 22.2	8 500 6 500	80 80
	180 230	– –	– –	8 500 6 500	80 80
	100	30	M 14	8 500	45

Starting Operation

Observe correct mains voltage: The voltage of the power source must agree with the voltage specified on the nameplate of the machine. Equipment marked with 230 V can also be connected to 220 V.

Switching On and Off

To **start** the machine, press the On/Off switch 3 forward and then down.

To **lock-on**, push the pressed On/Off switch 3 further forwards.

To **switch off** the machine, release the On/Off switch 3 or push and release it then.

Switch version without lock (country-specific):

To **start** the machine, press the On/Off switch 3 forward and then down.

To **switch off** the machine, release the On/Off switch 3.

Test run!

Check the grinding tool before use. The grinding tool must be properly mounted and rotate freely. Perform a test run of at least 30 seconds without load. Do not use damaged, out-of-round or vibrating grinding tools.

Operating Instructions

- **Clamp the workpiece if it does not remain stationary due to its own weight.**
- **Do not strain the machine so heavily that it comes to a standstill.**
- **Grinding and cutting discs become very hot while working; do not touch until they have cooled.**

Rough Grinding



The best roughing results are achieved when setting the machine at an angle of 30° to 40°. Move the machine back and forth with moderate pressure. In this manner, the workpiece will not become too hot, does not discolour and no grooves are formed.



Never use a cutting disc for roughing.

Flap Disc

With the flap disc (accessory), curved surfaces and profiles (contour sanding) can be worked.

Flap discs have a considerably higher service life than sanding sheets, lower noise level and lower sanding temperatures.

Cutting

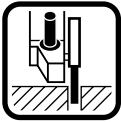

When cutting, do not press, jam or oscillate the machine. Work with moderate feed, adapted to the material being machined.

Do not reduce the speed of running down cutting discs by applying sideward pressure.

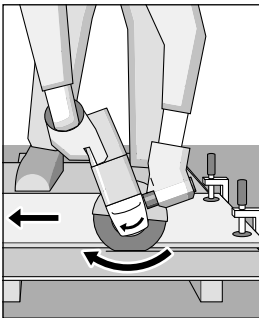

The direction in which the cutting is performed is important.

The machine must always work in an up-grinding motion. Therefore, never move the machine in the other direction! Otherwise, the danger exists of it being pushed **uncontrolled** out of the cut.

Grinder Stand

With the grinder stand 26 (accessory), workpieces can be cut at angles of 0 to 45° at the same lengths.

The safety notes and operating instructions in the respective operating instructions manual of the angle grinder are to be strictly observed. Use only original Bosch grinder stands.

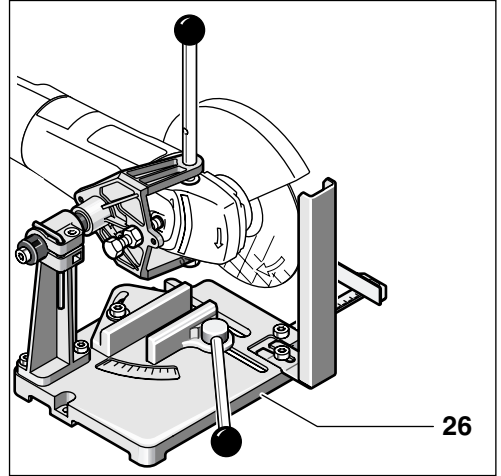

Cutting Stone

- **The machine must be used only for dry cutting/grinding.**

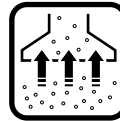

It is best to use a diamond cutting disc. As a safety measure against jamming, use the **cutting guide 25** with the special dust extraction protection guard.

Operate the machine with dust extraction only. In addition, wear a dust mask.

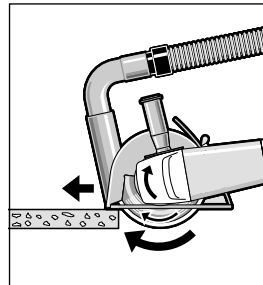

The vacuum cleaner must be approved for the extraction of masonry dust.

Bosch provides suitable vacuum cleaners.

Switch on the machine and place the front part of the cutting guide on the workpiece.

Slide the machine with moderate feed, adapted to the material to be worked (Figure).

For cutting especially hard material, e. g., concrete with high pebble content, the diamond cutting disc can overheat and become damaged as a result. This is clearly indicated by circular sparking, rotating with the diamond cutting disc.

In this case, interrupt the cutting process and allow the diamond cutting disc to cool by running freely at no-load speed for a short time.

Noticeable decreasing work progress and circular sparking are indications of a diamond cutting disc that has become dull. Briefly cutting into abrasive material (e. g., lime-sand brick) can re-sharpen the disc.

If the machine should fail despite the care taken in manufacturing and testing procedures, repair should be carried out by an after-sales service centre for Bosch power tools.

In all correspondence and spare parts orders, please always include the 10-digit order number given on the nameplate of the machine.

Service and Customer Assistance

Exploded views and information on spare parts can be found under:
www.bosch-pt.com

Southern India

Bosch Service Center
No 49, Ethiraj Salai
Egmore Chennai 600 008

☎ +91 (0)44 - 28 23 19 46
Fax: +91 (0)44 - 28 27 93 55

Western India

Bosch Service Center
No 41, 41 A Appa Baug Building
Maharshi Karve Marg (opp. Charni Road Station)
Mumbai 400 002

☎ +91 (0)22 - 22 01 46 49
Fax: +91 (0)22 - 22 08 40 05

Northern India

Bosch Service Center
Rishyamook, 85 A
Panchuin Road Delhi 110 001

☎ +91 (0)11 - 23 34 82 64
Fax: +91 (0)11 - 23 34 82 64

Subject to change without notice

Rotating the Machine Head

■ Before any work on the machine itself, pull the mains plug.

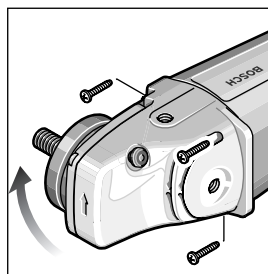

The machine head can be rotated with respect to the machine housing in 90° steps. In this manner, the On/Off switch can be brought to an advantageous handling position for special working situations, e. g., for cutting work

with the cutting guide 25/cutting grinder stand 26 (accessory) or for left-handed persons.

Unscrew completely the four screws.

Rotate the machine head carefully and **without removing from the housing** to the new position.

Screw in the screws again and tighten.

Maintenance and Cleaning

■ Before any work on the machine itself, pull the mains plug.

☞ For safe and proper working, always keep the machine and the ventilation slots clean.



In extreme working conditions, conductive dust can accumulate in the interior of the machine when working with metal. The protective insulation of the machine can be degraded. The use of a stationary extraction system is recommended in such cases as well as frequently blowing out the ventilation slots and installing a residual current device (RCD).

BOSCH
Ideas that work.

* Des idées en action.



Bosch Power Tool Division
Motor Industries Co Ltd
P B No 3000, Audugodi
Hosur Road,
Bangalore 560 030
Ph: + 91 (0)80 - 22 99 28 66/22 99 95 15

1 609 929 F75 (04.03) O/16
Printed in India - Imprimé en Inde